

Geneva Parcel Letterbox

Contents

Your carton should contain the following parts:

- 1 x Front Panel
- 1 x Back Box (Upper + Lower)
- 1 x Mounting Bracket (attached to the inside of the letterbox)
- 1 x Accessories Bag

Choosing a Suitable Location

The letterbox can be either mounted into a timber fence, or built into a brick or block wall. You will need to install it in a location that is easily accessible to Australia Post and couriers. The recommended height for the mail slot is 90 to 120cm from the ground.

Timber Fence Installation

Tools Required

- Drill + Timber Drill Bit
- Pencil
- Tape Measure
- Spirit Level
- Jigsaw

1. Open the parcel door. Detach the front panel from the upper box by unscrewing the 4 bolts pictured below.

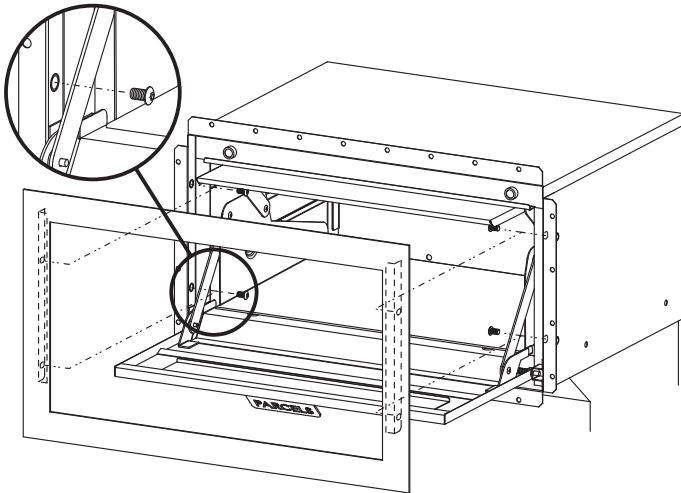

2. Detach the lower box from the upper box by unscrewing the 6 external bolts using the allen key supplied.

Open the parcel door, then open the rear door and unscrew the last 2 internal bolts.

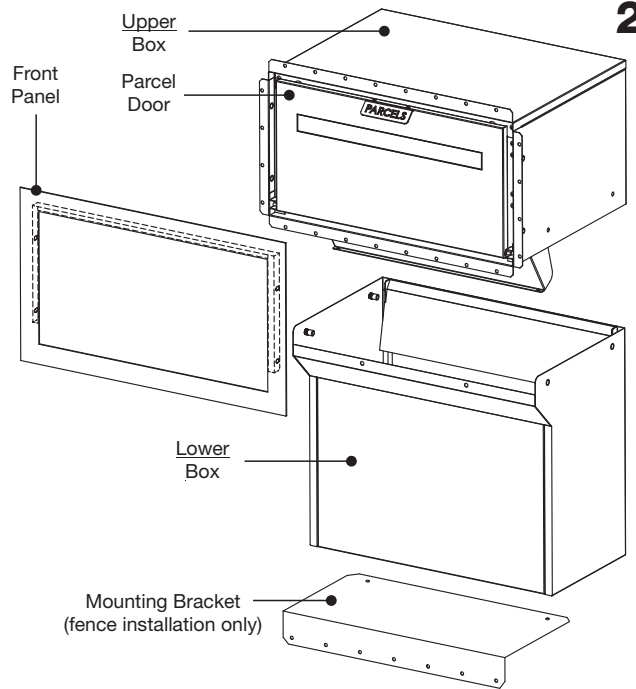
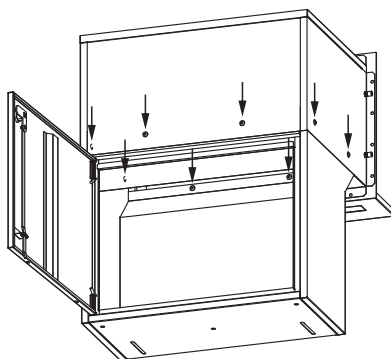

258

This step requires 2 people

3. 1st person - Press the upper box against the fence. Use a spirit level to ensure the box is level.

2nd person - Mark the fence around the box perimeter.

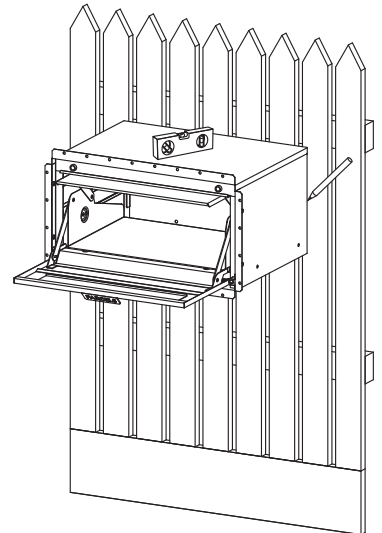

Safety Tip

Ensure you wear safety goggles before proceeding with the next step

4. Using a jigsaw, cut along the fence marking.

5. Gently push the upper box through the fence cutout as far in as possible.

Mark where to cut out the notches in the fence.

Remove the upper box and using a jigsaw, cut out the marked locations.

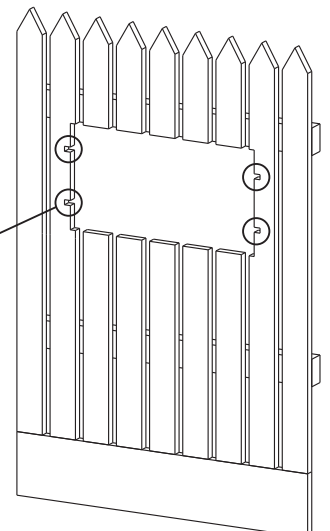

Timber Fence Installation (cont...)

6. Ensuring the parcel door is still open, fully insert the upper box through the cutout.

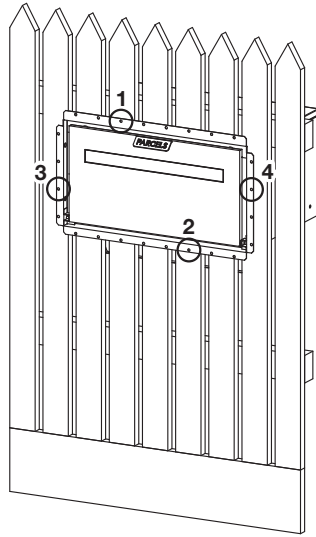

7. Close the door and secure in place with screws supplied, using the following sequence below;
 1st - top flange
 2nd - bottom flange
 3rd - left flange
 4th - right flange

Once the first 4 screws have been secured, then secure all the other screws into the timber.

8. To re-attach the front panel, place the front panel into the body. Open the parcel door and secure with the 4 bolts previously unscrewed in step 1.

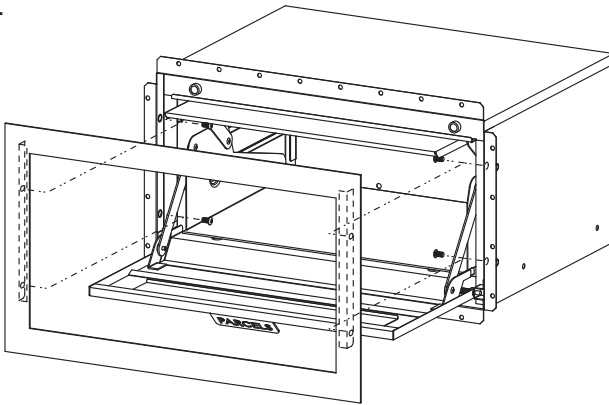

This step requires 2 people

9. Ensure the parcel door is still open.

1st person - Slide the lower box inside the base of the upper box, aligning the mounting holes. Hold in place.

2nd person - Screw in the 6 mounting bolts into the aligned holes.

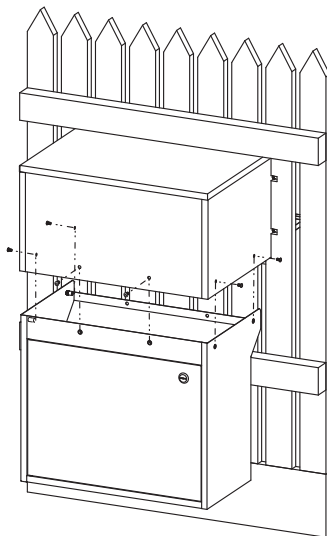

10. Open the rear door. Reach up inside the body, towards the front to secure the last 2 bolts.

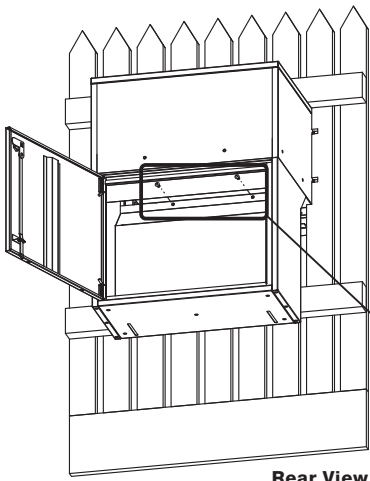
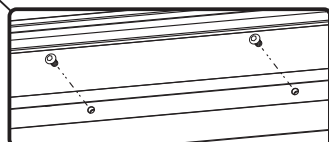

11. Detach the mounting bracket fixed to the inside of the letterbox by unscrewing the 2 sets of nuts and bolts.

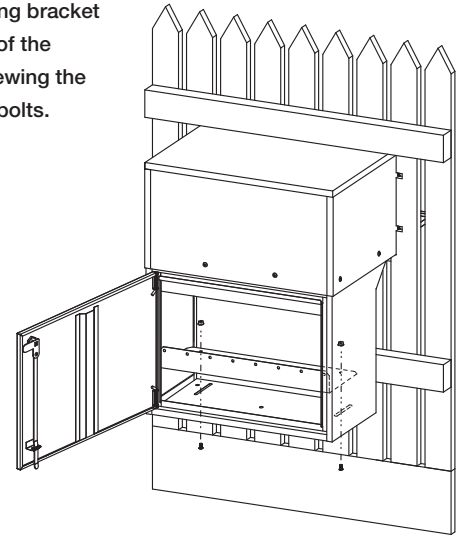

12. Re-attach the mounting bracket onto the underside of the letterbox loosely tightening the same 2 sets of nuts and bolts.

Slide the mounting bracket forward until it touches the rear of the fence.

Tighten the nuts to secure the mounting bracket in place.

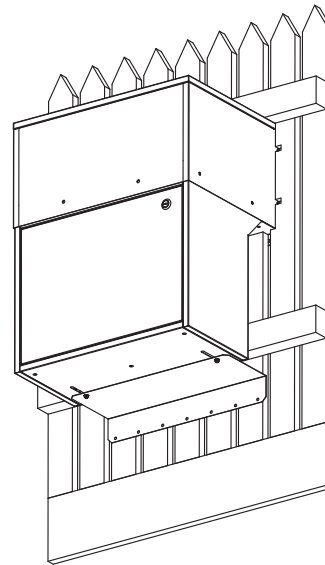

13. Secure the mounting bracket to the fence using the screws supplied.

Brick Wall Installation

1. Open the parcel door. Detach the front panel from the upper box by unscrewing the 4 bolts pictured below.

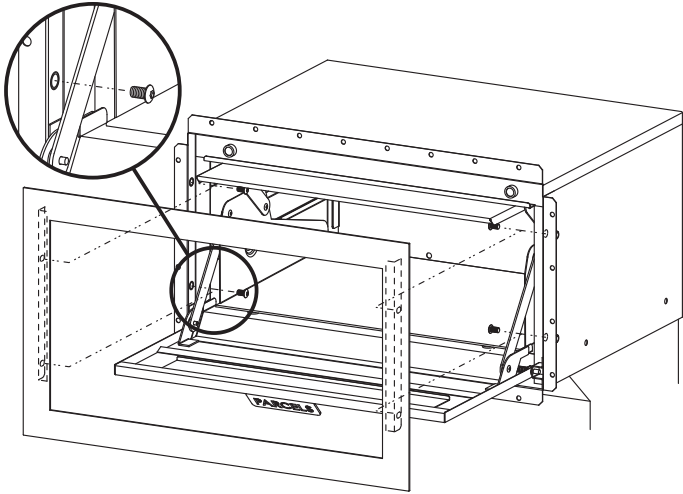

2. Build the brickwork up to the desired level and set the back box in place.

Plain brick walls - the front flanges should sit flush with the wall.

Rendered walls - set the back box forward so it will sit flush with the finished rendered surface

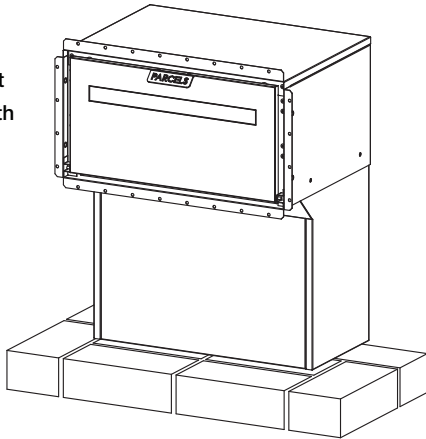

3. Build the brickwork up to the underside of the lower box

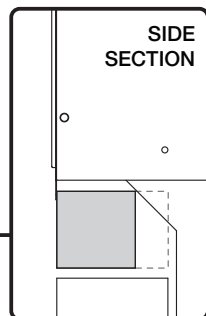
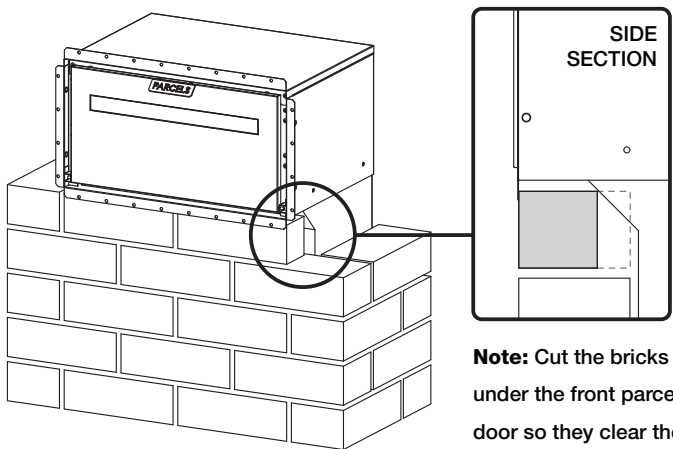

Note: Cut the bricks under the front parcel door so they clear the angled part of the body

4. Complete the remaining brickwork around the letterbox. Finish any brick cleaning or rendering.

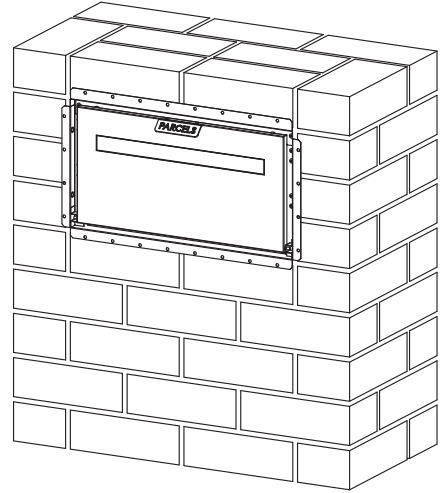

5. Once the brickwork and any rendering has been completed, re-attach the front panel.

Place the front panel into the body, open the parcel door and secure with the 4 bolts previously unscrewed in step 1.

