

Amalfi Letterbox

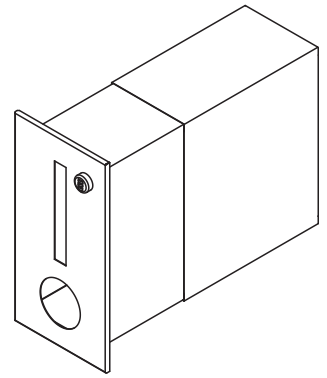

746B3
746F1

You will need to install the Amalfi letterbox in a location that is easily accessible to Australia Post and couriers. This will typically be at your front boundary. The ideal height for the mail opening is 90-120cm from the ground.

This letterbox is specially designed to allow parcel delivery. The courier simply enters the allocated combination code to unlock the front door, places the parcel inside, closes the door and re-toggles the combination.

When you purchase an item to be delivered, let the supplier know the parcel delivery instruction. For example, "PLACE IN LETTERBOX. USE CODE 321 TO OPEN".

Installation

1. Build the brickwork up to the desired height and set the sleeve in place following these guidelines;

IMPORTANT: STUDS MUST SIT TO LEFT SIDE OF LETTERBOX

Expand the rear sleeve according to your requirements, this will typically be either;

- Fully expanded to the rear of the pier
- Partially expanded so that bricks can be set in place behind the cap
- For plain brick walls, the front flanges should sit flush with the wall
- For rendered walls, set the front flanges so they will sit flush with the finished rendered surface.

2. Complete the remaining brickwork around the letterbox. Finish any brick cleaning or rendering.

3. Once the brickwork and any rendering has been completed and cleaned, attach the front panel by following the steps below.

4. Insert the locking arm by placing it through the guide slot.

5. Align the hinge holes with the corresponding studs. Secure the hinge using the washers and nuts provided.

MOUNTING STUDS
MUST BE ON THIS
SIDE

**WARNING: DO NOT
RENDER PAST THE
FRONT FLANGES,**
the finished render
surface must be flush
with the front flanges,
otherwise the door
will not work properly.

