

Chelsea Front Open Brick Letterbox

161

Contents

Your carton should contain the following parts:

- 1 x Front Panel
- 1 x Accessories Bag
- 1 x Sleeve

Choosing a Suitable Location

The letterbox can be either built into a brick or block wall. You will need to install it in a location that is easily accessible to Australia Post and couriers.

The recommended height for the mail slot is 90 to 120cm from the ground.

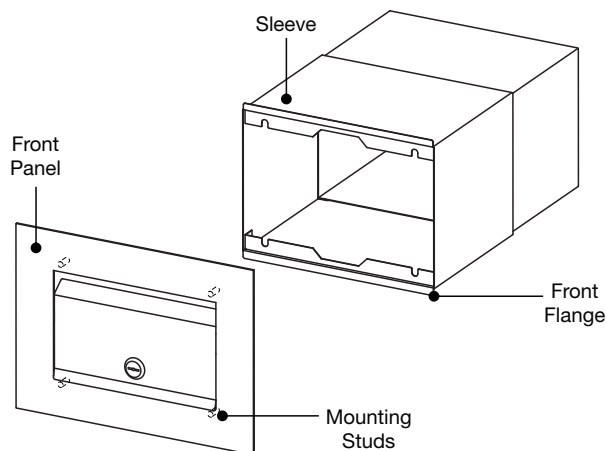

Removing the Front Panel for Installation

1. Reach through the front sleeve (with front panel attached) and unscrew the 4 x mounting nuts.
2. Gently pull the front panel to remove from the sleeve.
3. Re-assemble the front and rear sleeves prior to installation.

Installation

1. Build the brickwork up to the desired level and set the sleeve in place.

Plain brick walls - the front flanges should sit flush with the wall.

Rendered walls - set the front flanges forward to allow for the render thickness.

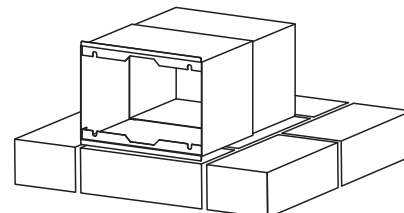

2. Complete the remaining brickwork around the letterbox.

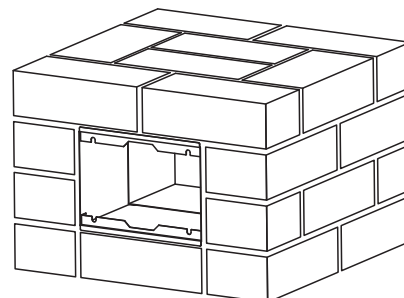

3. Once the brickwork and any rendering has been completed, attach the front panel by inserting the 4 x mounting studs through the corresponding holes in the front sleeve.

Open the front door and reach through to secure with the nuts provided.

