

Windsor Fence Letterbox

230

Tools

Required

- Drill
- Timber Drill Bits
- Tape Measure
- Jigsaw

Contents

- Your carton should contain the following parts:
- 1 x Front Panel
 - 1 x Back Box
 - 1 x Accessories Bag

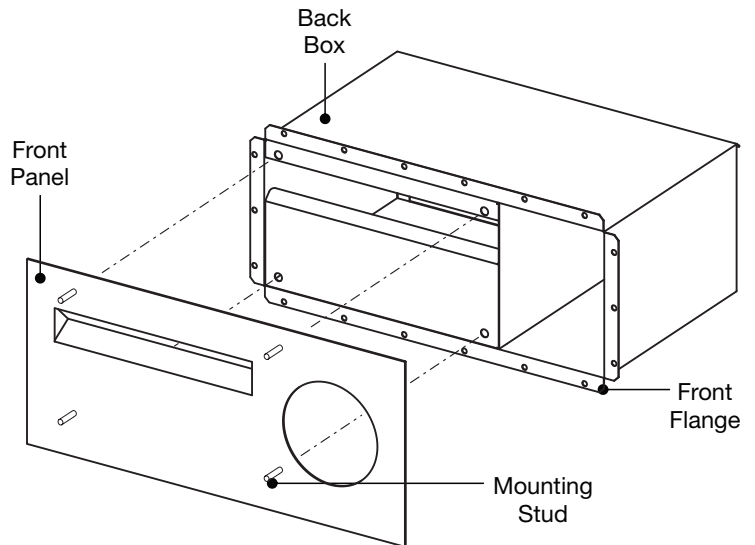

Choosing a Suitable Location

The letterbox can be either mounted into a timber fence, or built into a brick or block wall. You will need to install it in a location that is easily accessible to Australia Post and couriers. The recommended height for the mail slot is 90 to 120cm from the ground.

Timber Fence Installation

1. Remove the front panel by undoing the four mounting nuts from inside the back box.

2. Measure the back box, mark and cut a slightly larger hole into the fence using a jigsaw.

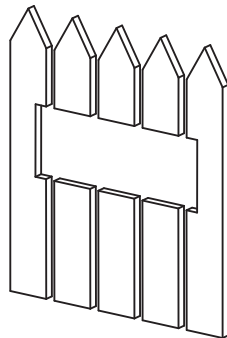

3. Slide the back box through the front of the fence. Screw it to the fence with the screws provided (for hardwood fences, it is easier to pre-drill the screw holes).

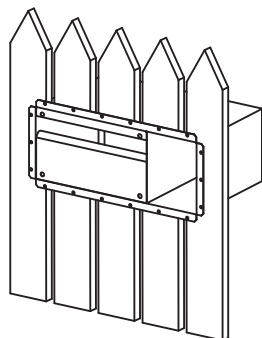

4. Attach the front panel by inserting its four mounting studs through the corresponding holes in the back box. Secure with the nuts provided.

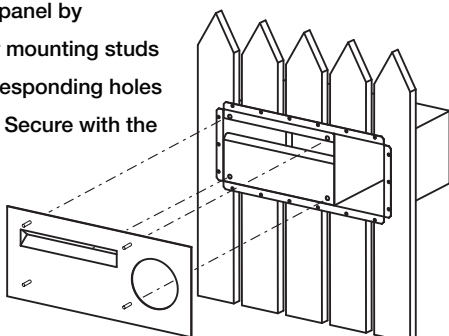

Brick Fence Installation

1. Remove the front panel by undoing the four mounting nuts from inside the back box.

2. Build the brickwork up to the desired level and set the back box in place. Plain brick walls - the front flanges should sit flush with the wall. Rendered walls - set the back box forward to allow for the render thickness.

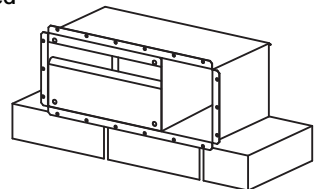

3. Complete the remaining brickwork around the letterbox.

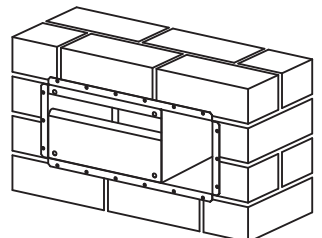

4. Once the brickwork and any rendering has been completed, attach the front panel by inserting its four mounting studs through the corresponding holes in the back box. Secure with the nuts provided.

