

11 Line Fold Down Clothesline

MCL13042

Tools

Required

- Drill / Hammer drill (ideal)
- Timber or Masonry Drill Bits
- Tape Measure
- Spanner
- Pencil

Optional

- Spirit Level
- Hack Saw (if shortening width)

Contents

Your carton should contain the following parts:

- 2 x Wall Brackets
- 2 x Side Arms (assembled)
- 2 x Front Bars
- 1 x Front Brace
- 1 x Line Cord
- 1 x Accessories Bag

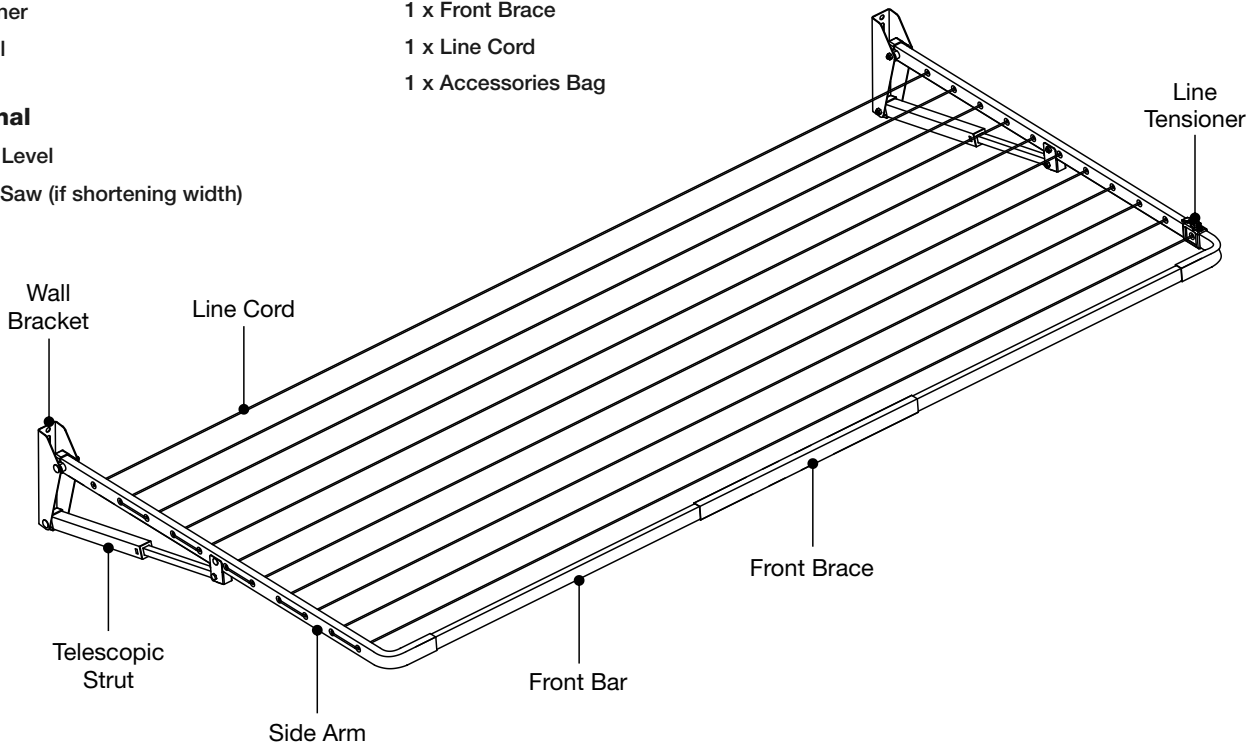

Choosing a Suitable Location

The recommended mounting height of the top slotted hole in the wall bracket is: **USERS HEIGHT + 10cm**. Minimum height is 160cm.

Installation and Assembly

If you are using a Milkcan Ground Mount Kit, skip steps 1 & 2 and refer to instructions inside the ground mount kit packaging.

1. Mark position of wall brackets to an overall width of 240cm between centres. If your required width is less than 240cm, please refer to [Reducing the Overall Width](#) below.

Reducing the Overall Width

If your available space doesn't allow the full 240cm width, you can reduce the width of your Clothesline as follows:

- For this example, we are assuming your required overall width is 200cm. This is a total reduction of 40cm.
- Cut half from each side of the 2 x cross bar segments i.e. $40 / 2 = 20\text{cm}$ each side

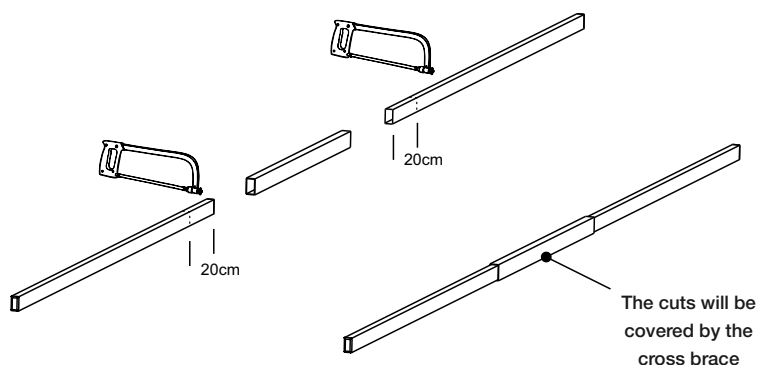

Installation and Assembly (cont...)

2. Attach the wall brackets to your brick wall or timber posts.

- For brick walls, use the M8 (10mm) masonry anchors provided
- For timber posts, use the M10 coach screws provided

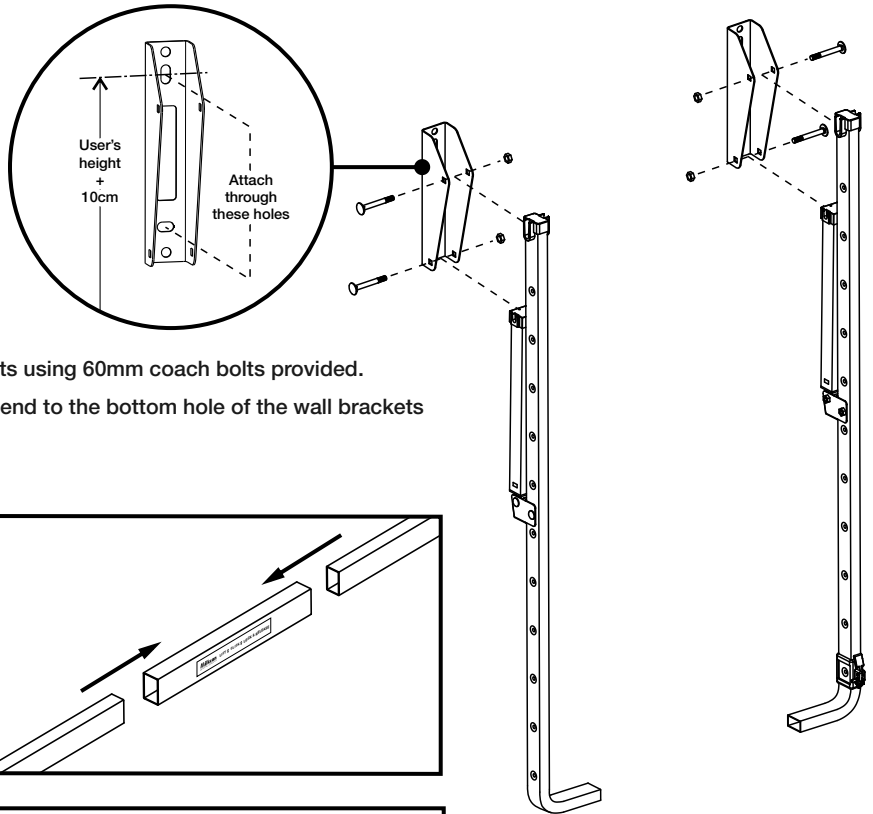

3. Fit the side arms to the top hole of the wall brackets using 60mm coach bolts provided.

Cut the cable tie securing the strut and fit the free end to the bottom hole of the wall brackets using the 60mm Coach bolts and nuts provided.

4. Assemble the front bar, pushing the left and right bars fully into the front brace until they hit the small indent in the middle of the front brace.

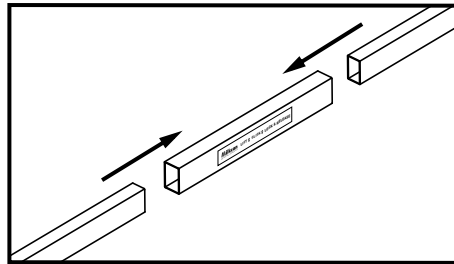

5. Spread the side arms slightly apart and insert the assembled front bar into the corners as shown right.

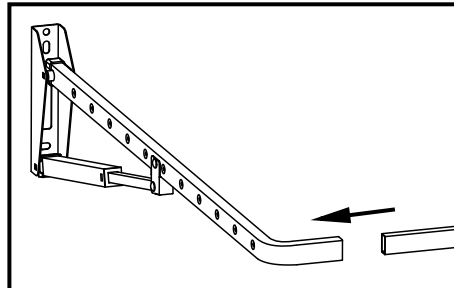

Line Cord Installation

1. Ensure the Line Tensioner is at the front of the right hand side arm.

2. Start threading the line cord through the left side arm hole nearest the wall bracket. Tie off the end as shown right.

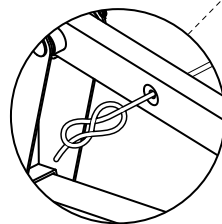

3. Progressively tighten each line, starting from the rear, working towards the front. Don't over-tighten or you will distort the side arms.

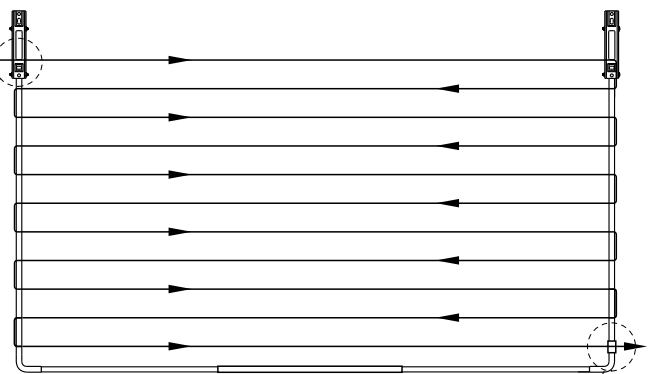

4. Thread the cord through the Line Tensioner as shown. Lift the clamping lever up before threading the cord. Push the lever down to clamp the cord.

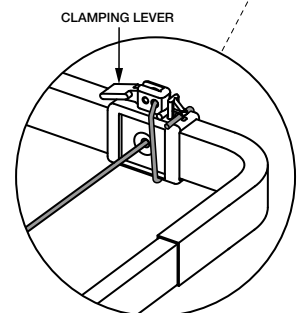

Using your Clothesline

To Raise Slowly lift the front bar until you hear a single click from each strut.

To Lower Lift the front bar higher until you hear another click from each side. It can now be folded fully down.

Ground Mount Kit

MCL13031

Tools

Required

- Tape Measure
- Spanner

Optional

- Spirit Level
- Hack Saw
(if shortening width)

Contents

Your carton should contain the following parts:

- | | |
|----------------|---------------------|
| 2 x Posts | 1 x Cross Brace |
| 2 x Cross Bars | 1 x Accessories Bag |

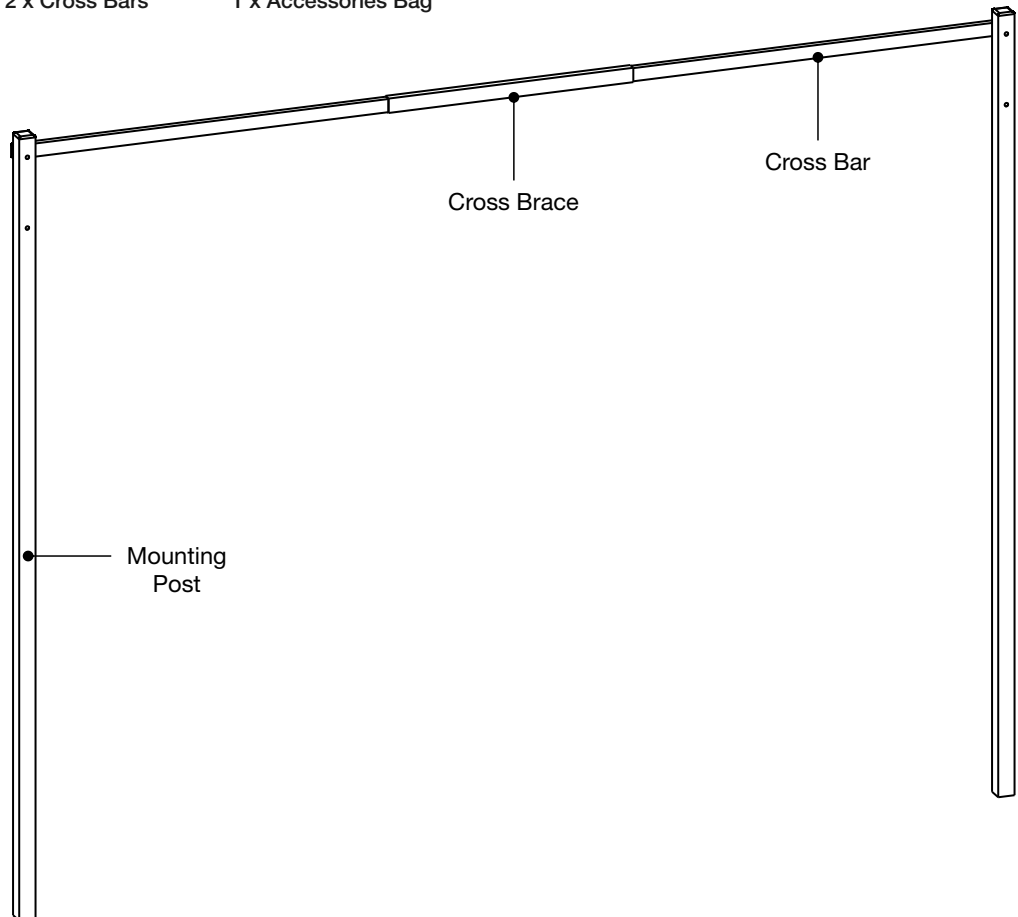

Choosing a Suitable Location

The recommended mounting height of the top slotted hole in the wall bracket is: **USERS HEIGHT + 10cm**. Minimum height is 160cm.

The Clothesline and Ground Mount Kit are 240cm wide. If your required width is less than 240cm, please refer to [Reducing the Overall Width](#) below.

Reducing the Overall Width

If your available space doesn't allow the full 240cm width, you can reduce the width of your Clothesline as follows:

- For this example, we are assuming your required overall width is 200cm. This is a total reduction of 40cm.
- Cut half from each side of the 2 x cross bar segments i.e. $40 / 2 = 20\text{cm}$ each side

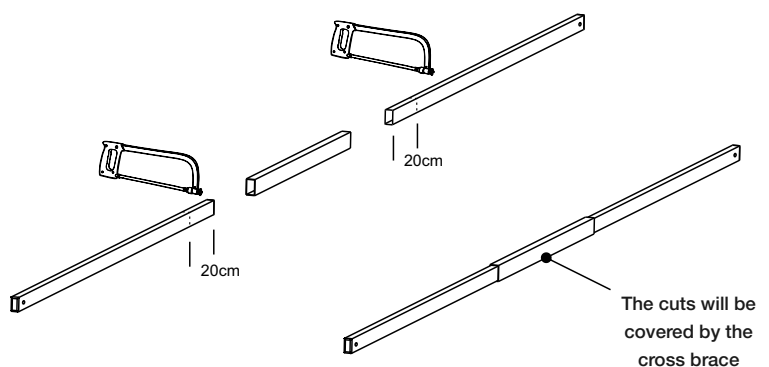

Assembly

1. Assemble the cross bar. Push the left and right bars fully into the cross brace until they hit the small indent in the middle. Fix into place using the 2 x screws supplied.
2. Attach the assembled cross bar and Clothesline wall brackets to the Ground Mount posts.
3. Before installation we suggest attaching the clothesline assembled side arms to the wall brackets. Please refer to Step 3 on the clothesline instruction sheet. Don't attach the Clothesline front bar or line cord yet, this will be done later.

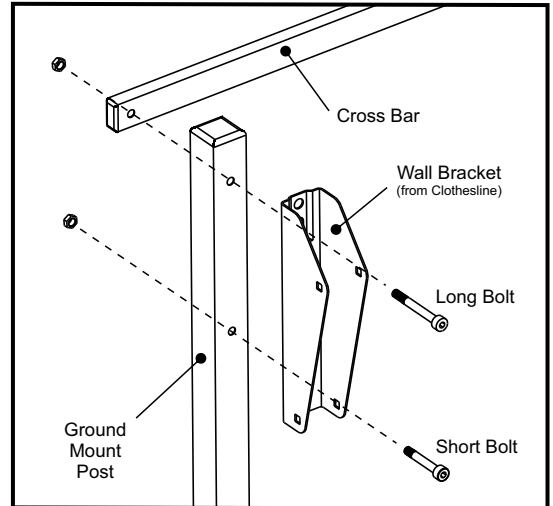
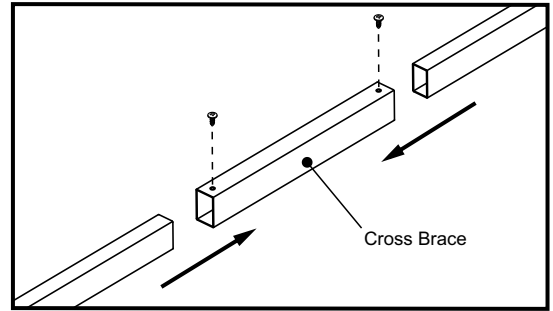

If you are using the Mounting Plate Kit, continue installation using the instructions included in your Mounting Plate Kit packaging.

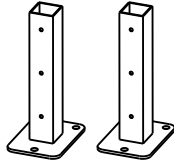

Installation

1. In your chosen location, mark two holes on the ground 240cm apart (or your chosen width) for the posts.
2. Dig the two holes to a depth of 40cm and fill with 5cm of gravel to allow for drainage.
3. Place the assembled Ground Mount Kit into the holes you've just dug. The cross bar should be 10cm above the typical users height. The height of the cross bar can be adjusted by cutting the Mounting Posts down in height (only cut the end that goes in the ground).
4. Concrete the Mounting Posts into the holes, checking the following before and during concreting:-
 - Post spacing is 240cm between centres (or your chosen width).
 - Mounting Posts are vertical - check with a spirit level.
 - Cross bar is horizontal - check with a spirit level.
5. Clean any excess concrete from the posts with a damp cloth. Allow the concrete to set for 24 hours before attaching the Clothesline front bar and line cord.

